

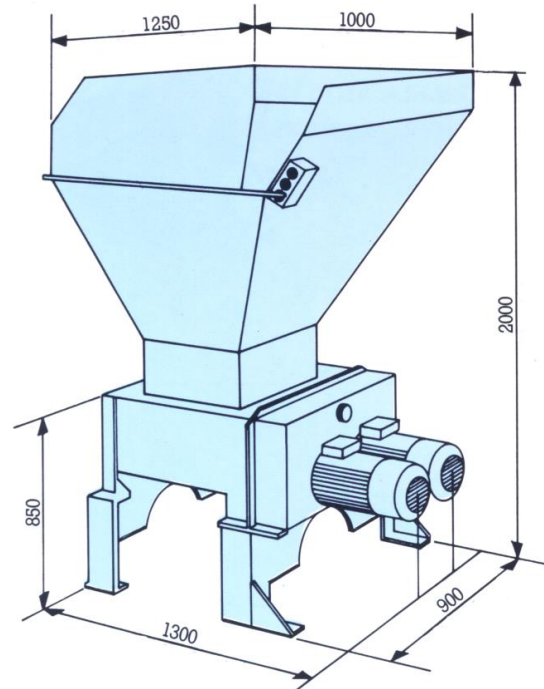

HIGGINS BALERS LTD

RENEWING, REPAIRING, REPLACING

UNTHA RS40 FOUR SHAFT SHREDDER



SUMMARY SPECIFICATION

DETAILS	IMPERIAL	METRIC
Machine Weight	2000 lbs	1700 kg
Shred Cutter Width	3/4"	19 mm
Motor Size	2 x 20 hp	2 x 18.5 kW
Voltage		415 V
No of Hooks		Varies
Shredding Depth	27 1/2"	700 mm
Shredding Width	29 1/2"	750 mm

MEASUREMENTS MAY VARY DUE TO MANUFACTURER'S POLICY OF IMPROVEMENT
Images are representative of equipment and not necessarily of the actual item available

